

SPECIFICATION

ARTICULATED TRAVELLER CAR, SHEAVE Ø100

ATTRIBUTE	VALUE
CODE	91791
MATERIAL	STAINLESS 316L
SHEAVE MATERIAL	ALUMINUM
SIDE BEARING	DERLIN BALLS
RADIAL BEARING	TORLON ROLLERS
MAXIMUM WORKING LOAD	7500kg
MAX LINE Ø	20mm
WEIGHT	10,5kg
Ø SHEAVE (A)	100mm
B	250mm
C	460mm

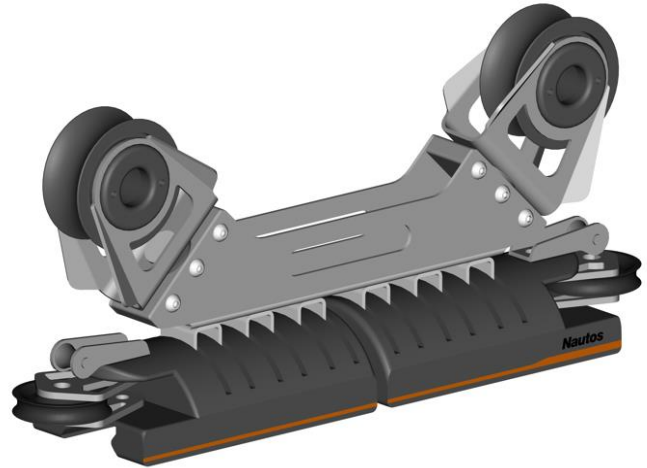

WARRANTY: 5 YEARS

